

MINIMIX 150

NOTE: USED IN PRODUCTION, FROM APRIL 2002 (ON 230v-50HZ + 110v-50HZ)

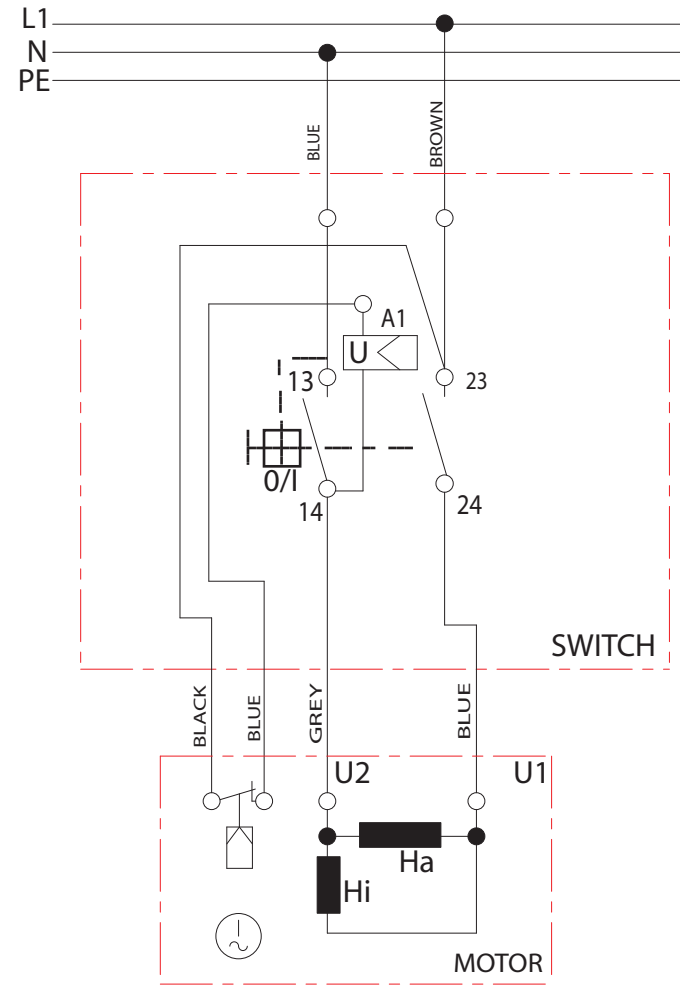
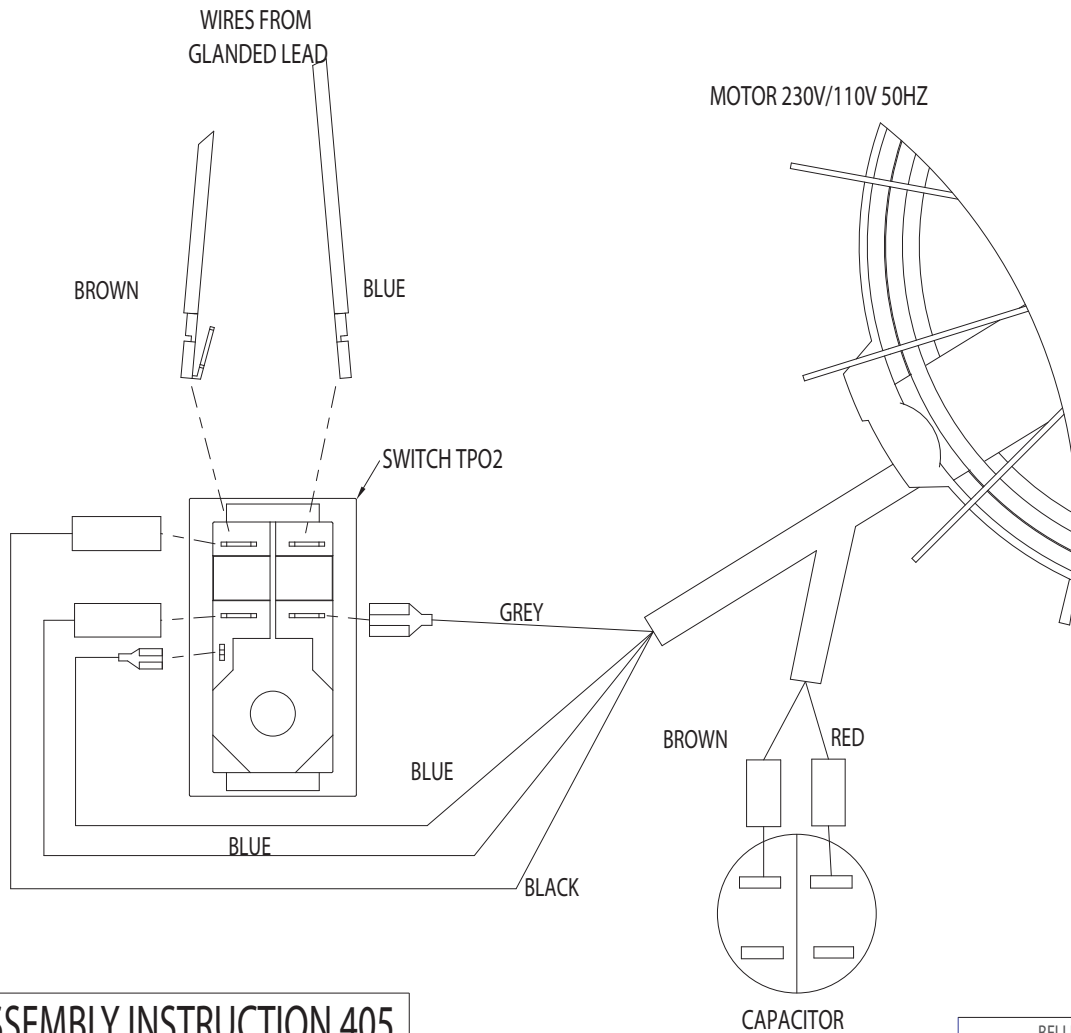

ASSEMBLY INSTRUCTION 405

5				
4				
3				
2				
1				
	ECN No.	DESCRIPTION	DATE	DRN

BELLE ENGINEERING LTD.

SHEEN, BUXTON, DERBYSHIRE. SK17 0EU

MACHINING:
 LINEAR DIMS & HOLE CENTRES ±0.5mm ANGLES ±0.5°
 HOLES UP TO 8mm -0 +0.16 HOLES OVER 8mm -0 +2% OF DIA.
 FABRICATION DETAILS:
 0-500mm ±1mm 500-2000mm ±1.5mm OVER 2000mm ±3mm ANGLES ±1°
 FABRICATION ASSEMBLIES:
 0-1000mm ±1.5mm 1000-2000mm ±3mm OVER 2000mm ±6mm ANGLES ±1°
 SURFACE TEXTURE VALUES IN MICROMETRES

Drg. No.	A10405-0	ECN No.	E2809
Desc.	ASSEMBLY - MINI 150 TPO2 SWITCH		
Drawn.	M.J.HALL	Date.	25 JAN 2002
Scale.	1:1	Weight.	N/A
Material.	N/A		