



BELLE  
LIGHT  
CONSTRUCTION  
EQUIPMENT



# DX 1000<sub>HT</sub>

## 1-TONNE HI-TIP DUMPER



BELLE  
LIGHT  
CONSTRUCTION  
EQUIPMENT

# dX 1000ht 1-tonne hi-tip dumper

## A DIAMOND IN THE ROUGH!!

The **BRAND NEW** DX 1000HT is the new **No.1** Best in Class 1-tonne high-tip dumper. Designed to be owned by a rental company or professional operator.

The DX 1000HT sets new standards for safety, strength, operator comfort and convenience and productivity on site. With a proven, reliable Yanmar 3TNV76, 3 cylinder, water-cooled Diesel engine - perfect for this application.

### FEATURES & BENEFITS

#### Operator Comfort and Convenience

- Fuel level is visible while in the operator's seat, saving time & improving safety & down time.
- Increased leg room for improved operator comfort.
- USB phone charger point, allowing charging while the work is done.
- Leading brand, comfort seat compliant to latest standards EN ISO 7096 for this type of equipment. Reduces operator fatigue, improves operator experience.

#### Strength

- Robust, easy-clean skip with fully returned edges preventing dirt ingress / concrete accumulation, reducing down time and cleaning costs.
- Strengthened chassis rails to increase durability.
- High quality, shot-blast and 2-layer powder coated paint finish for the most demanding site conditions. Maximising resale values.
- Bushed & greased steering pivot cylinder, preventing wear on the main components, cost efficient for the owners.
- Steel belly pan protector prevents damage to hydraulic circuit.
- Front enclosure / infill plate reduces stone / mud ingress meaning less down time & cleaning required.
- Steering Ram - Hose guard cover plate to prevent damage.
- Hi-quality leading brand all-terrain tyres fitted with valve protect guard, to reduce down time on site and increase productivity.



**HIGH-QUALITY, ALL-TERRAIN TYRES WITH VALVE PROTECT GUARD & WHEEL NUT INDICATORS**



**ROBUST, EASY-CLEAN 1000KG CAPACITY SKIP FULLY RETURNED EDGES TO PREVENT DIRT INGRESS**

## Productivity

- The Altrad full 4 wheel drive system hydraulic system gives increased traction on poor terrain and excessive mud. Better gradeability, increased productivity and less servicing.
- Reliable, Yanmar 3TNV76, water-cooled Diesel engine - perfect for this application.
- Market leading fuel tank capacity, reduces amount of fill-ups and down time.
- Unique fuel level indicator window together with a low fuel level warning light allows for easy inspection and assist in ensuring rental & machine productivity high.
- Low hydraulic fluid level warning light reducing system damage and down time.
- Extensive use of hose clamp retainers to prevent pipe fretting and rubbing, reducing hose failures and maintenance costs.
- Fuel and Hydraulic tank drain points reducing tank flushing time in the event of contamination or servicing.
- Fuel - water separator reducing engine damage and down time.
- Central Hydraulic hoses enables increased protection, reducing the risk of down time.
- Under footplate - stone guards preventing stone/mud ingress, so less down time & cleaning required.



## Safety

- Emergency Stop Button for increased safety.
- Tight turning circle allows better manoeuvrability on tight work sites, reducing shunting and increasing safety, productivity & efficiency.
- High viz access points & anti-slip foot-steps reduces slips, trips and falls when climbing on and off machine. Easily replaceable in case of an impact.
- Auto retracting seat belt prevents entanglement. Bright Orange for safety with increased visibility.
- Safe heavy duty, easy to deploy steering lock out bar, makes workshop and transport actives safer.
- "Check Point" visual wheel nut indicators make daily checks simpler to perform, reducing machine down time.
- Enclosed document box to retain machine safety documents reducing possibility of being damaged / misplaced
- Lockable seat pan - gas strut c/w lock out reduces chance of head / trapping injuries.
- Anti-slip, hot-dipped galvanised floor plate for safety and long life.
- Hazard warning chevron's on rear of dumper for increased machine visibility on site to others.
- Priority / safety steering valve that gives priority to the steer function in the event of low hydraulic fluid pressure or flow, therefore maintain-highest levels of machine safety at all times.



**ROBUST STEEL, FRONT MATERIAL INGRESS GUARD PREVENTS DAMAGE TO HYDRAULIC CIRCUIT**

## DX 1000 1-TONNE HI-TIP DUMPER

Part Number .....DX10HYSA

### PERFORMANCE

Payload	(kg)	1000
Unladen Weight	(kg)	1363
Tipping Type		Front Tip - High
Turning Circle of Skip	(mm)	2637
Turning Circle of Tyres	(mm)	2524
Steering Angle	(°)	39.7
Body Oscillation Angle	(°)	15

### CAPACITIES

Skip - Water	(Ltr)	280
Skip - Struck	(Ltr)	400
Skip - Heaped	(Ltr)	500
Fuel Tank	(Ltr)	35
Hydraulic Oil Tank	(Ltr)	18

### ENGINE

Engine Model		Yanmar 3TNV76
Type		Diesel
No. of Cylinders		3
Gross Power	(Hp/kW)	21.4 / 15.9
Displacement cc	(cc)	1116
Max. Torque	(Nm)	66.4

### HYDRAULIC SYSTEM

Pump Type		Gear Pump
Flow Rate	(l/min)	30
Operating Pressure	(bar/PSI)	140
Steering System		Hydraulic

### BRAKING SYSTEM

Working Brake		Hydrostatic Dynamic Breaking
Parking Brake		Failsafe Automatic



**GOOD ACCESS TO KEY FEATURES WITH SELF-LOCKING GAS STRUT AND PROVEN YANMAR 3TNV76 DIESEL ENGINE**

### TRANSMISSION / DRIVE

Transmission Type		Hydrostatic Pump to 4 radial piston Hydraulic Motors
Tyre Size		255 / 75 -15.3
Drive		Hydrostatic
Max. Travel Speed	(kph)	12 (Unladen)
Max. Gradient		25% (4:1)

### ENVIRONMENTAL

- Sound Pressure	(LpAd)	84
Sound Power Level	(LWAd)	101
Noise Emission (to ISO 4871)		

### ELECTRICAL SYSTEM

System Voltage	(V)	12
Battery Capacity	(Ah)	44
Alternator Output	(A)	40

### STANDARD EQUIPMENT

Folding ROPS Frame	✓
Reversing Alarm	✓
Flashing Orange Beacon	✓
Hourmeter	✓
Seat Belt (Hi-Viz Orange)	✓
Adjustable Seat	✓
Heavy Duty Articulation Lock	✓
Wide Tyres	✓



**ERGONOMIC OPERATOR STATION WITH EASY-TO-REACH CONTROLS, LEADING BRAND COMFORT SEAT AND GOOD ALL-ROUND VISIBILITY**

## STATIC DIMENSIONS\*

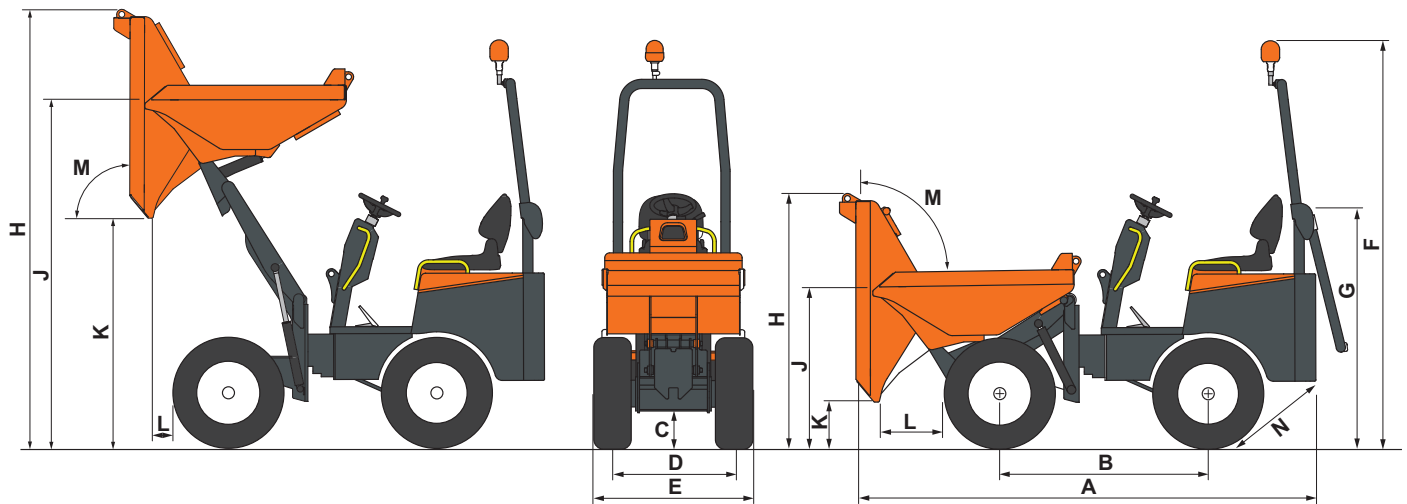

<b>A</b> - Overall Length.....	(mm)	3190
<b>B</b> - Wheel base .....	(mm)	1440
<b>C</b> - Minimum ground clearance .....	(mm)	250
<b>D</b> - Track width.....	(mm)	850
<b>E</b> - Width over tyres.....	(mm)	1100
<b>F</b> - Height to top of ROPS (raised, with/without beacons) .....	(mm)	2545 / 2800
<b>G</b> - Height to top of ROPS (folded) .....	(mm)	1630
<b>H</b> - Dump Height (untipped/tipped) .....	(mm)	1820 / 2960
<b>J</b> - Height to front lip of dumper body (untipped, lowered/raised) .....	(mm)	1110 / 2270
<b>K</b> - Height to front lip of dumper body (tipped, lowered/raised) .....	(mm)	400 / 1540
<b>L</b> - Discharge distance front (lowered/raised).....	(mm)	520 / 380
<b>M</b> - Dumper body tip angle .....	(°)	81
<b>N</b> - Departure angle .....	(°)	38

## OPTIONS

### Option Ready

- Green Beacon ready - fitted with seat belt sensor & main harness is ready to take Green Beacon option.
- Twin Beacon and work light approved ROPS structure.
- Fully loaded chassis harness - ready for options to be plugged in and used.
- Option ready console - ready for options to be plugged in and used.
- Customer colour options giving excellent brand awareness.

### Options Available

Work Lights x 2	OPD/20/DIO
Work Lights x 4	OPD/21/DIO
Green Beacon	OPD/22/DIO



**GREEN BEACON OPTION , 2X & 4X WORK LIGHT OPTIONS  
WITH LOCKABLE UNDER-CANOPY BEACON STORAGE**



BELLE  
LIGHT  
CONSTRUCTION  
EQUIPMENT

ALTRAD BELLE  
Sheen, Nr. Buxton, Derbyshire, SK17 0EU, GB  
Tel. +44 (0)1298 84606 - Fax +44 (0)1298 84722 - Email: [sales@altrad-belle.com](mailto:sales@altrad-belle.com)  
[www.Altrad-Belle.com](http://www.Altrad-Belle.com)  
[www.ALTRAD-Belle247.com](http://www.ALTRAD-Belle247.com)